

## Inscribed, Escribed and Circumscribed exercises.

Carry out the following exercises as accurately and neatly as possible.

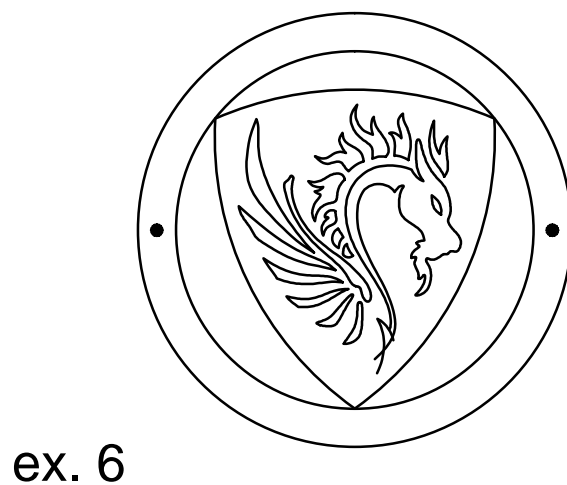
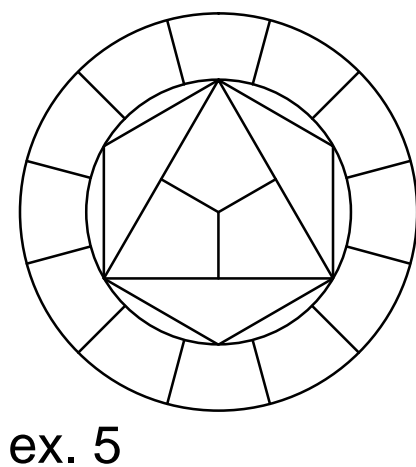
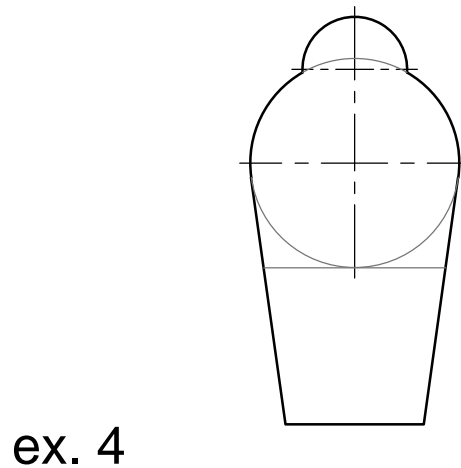
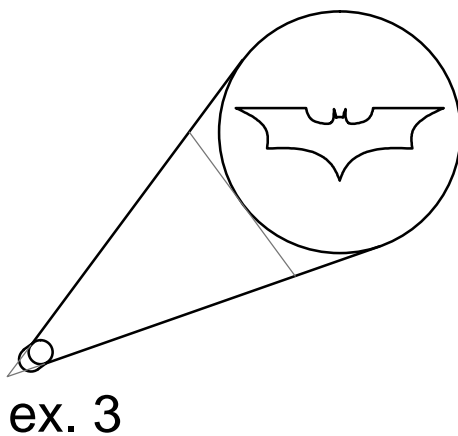
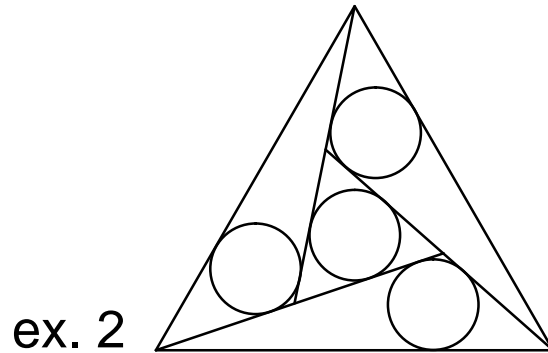
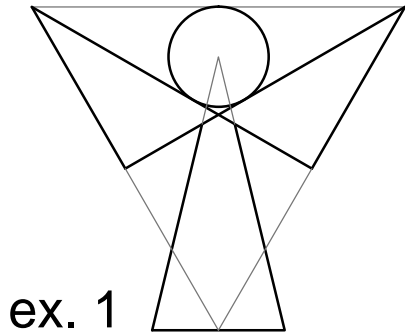

You can visit: <https://youtu.be/PGWgM3oeAag> for a step by step video of the construction methods.

## Inscribed circle exercise 1 - STARTER SHEET

Complete the angel by following these steps:

- a) construct an upside down equilateral triangle of sides 110mm
- b) draw the wings from the vertices to the midpoint of the sides
- c) inscribe a circle to represent the head
- d) complete the drawing

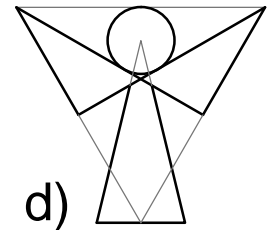
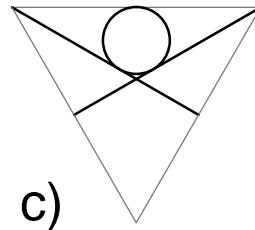
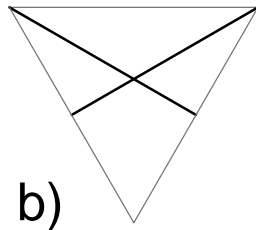
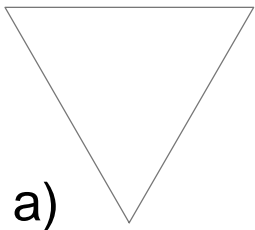

---

## Inscribed circle exercise 1 - ANSWER SHEET

Complete the angel by following these steps:

- construct an upside down equilateral triangle of sides 110mm
- draw the wings from the vertices to the midpoint of the sides
- inscribe a circle to represent the head
- complete the drawing

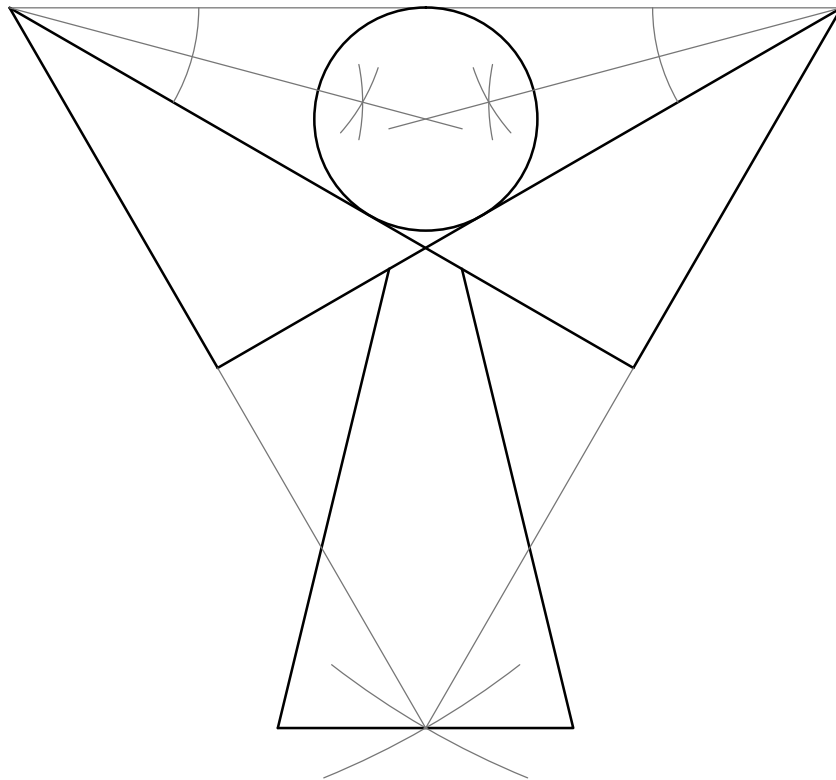
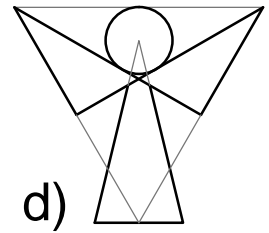
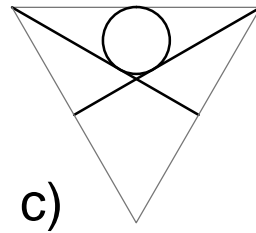
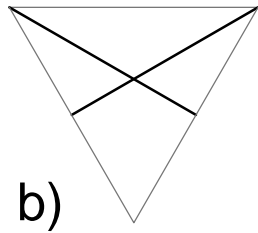
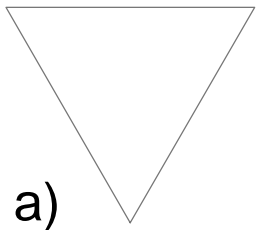

## Inscribed circle exercise 2 - STARTER SHEET

Complete the diagram by drawing inscribed circles in all the triangles.

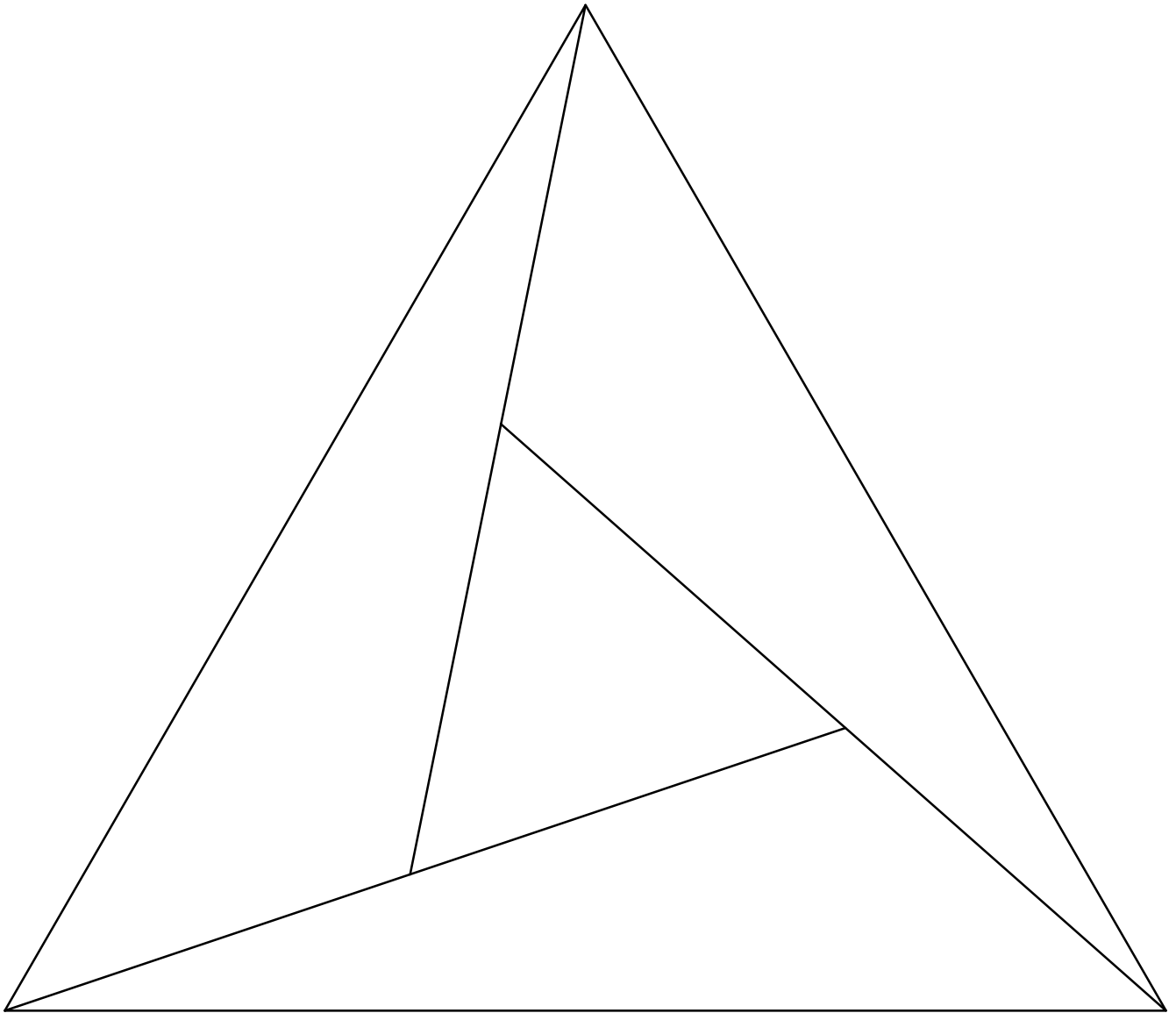
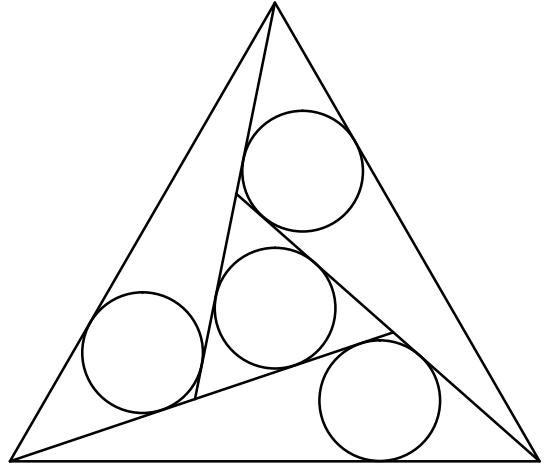

## Inscribed circle exercise 2 - ANSWER SHEET

Complete the diagram by drawing inscribed circles in all the triangles.

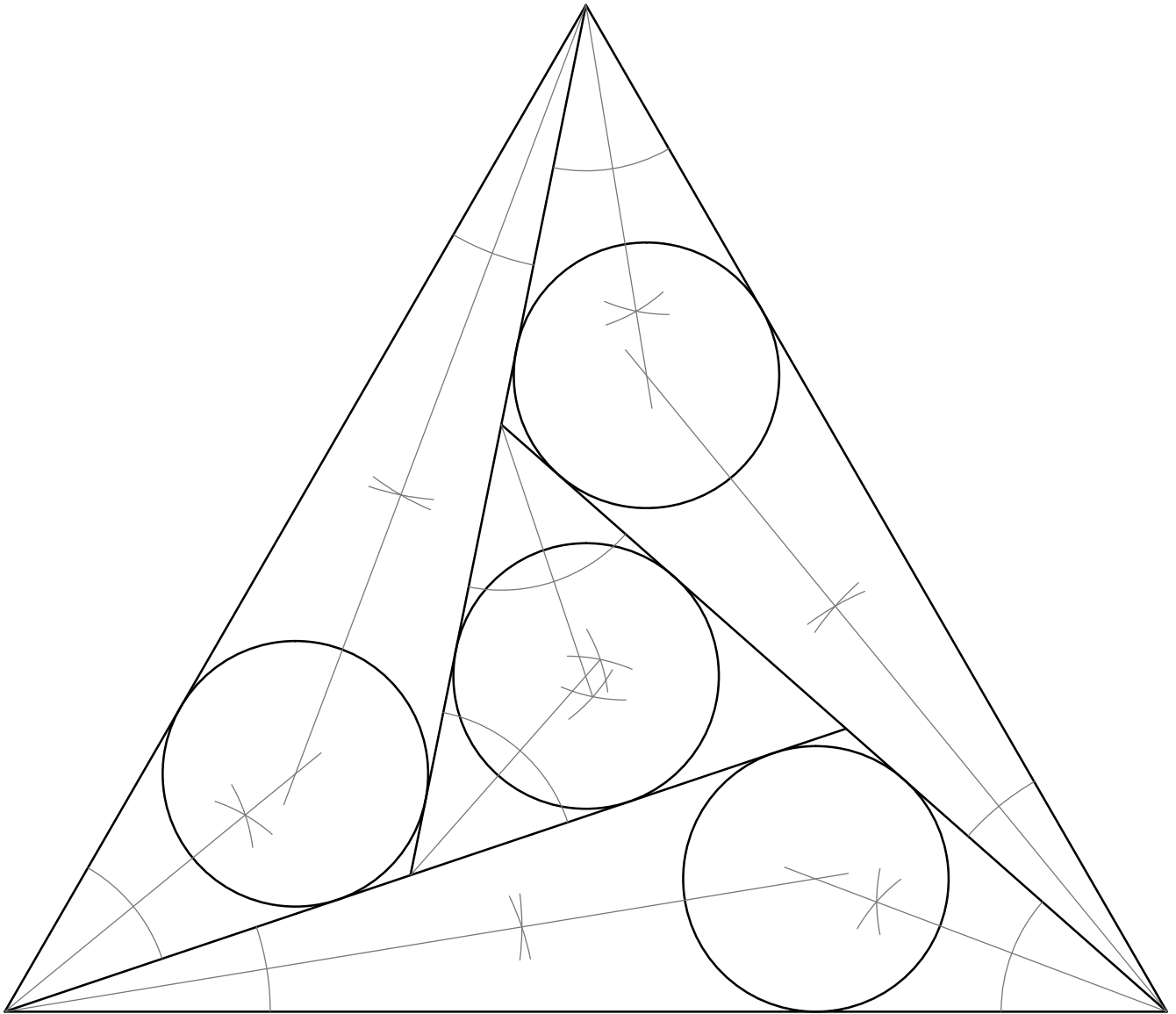
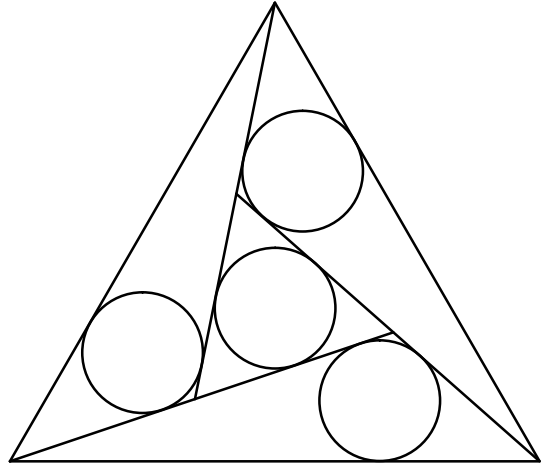

## Escribed circle exercise 1 - STARTER SHEET

Complete the Batman searchlight logo by:

- Extending the lines of the triangle
- Escribing a circle
- Finishing off your drawing

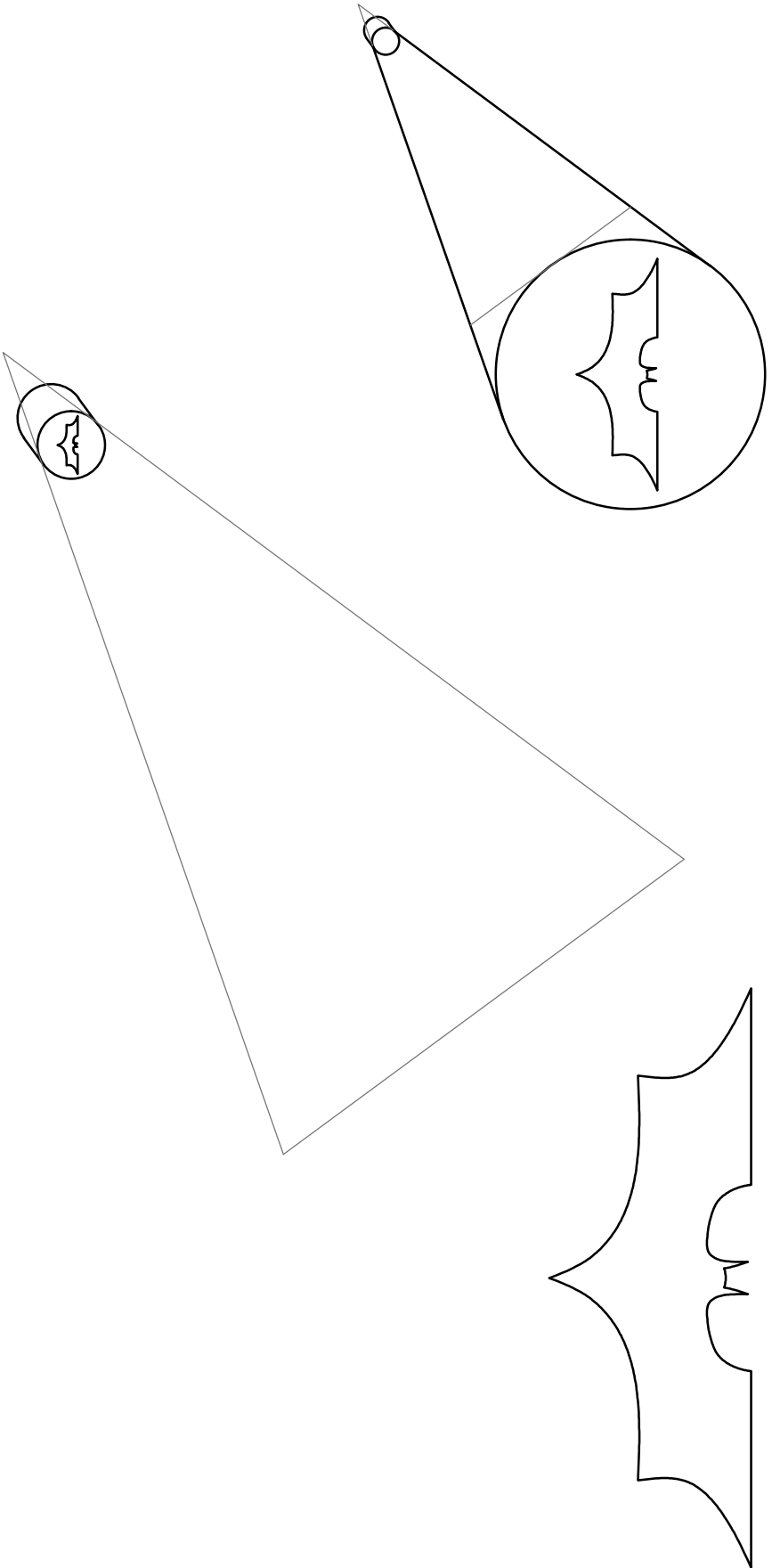

## Escribed circle exercise 1 - ANSWER SHEET

Complete the Batman searchlight logo by:

- Extending the lines of the triangle
- Escribing a circle
- Finishing off your drawing

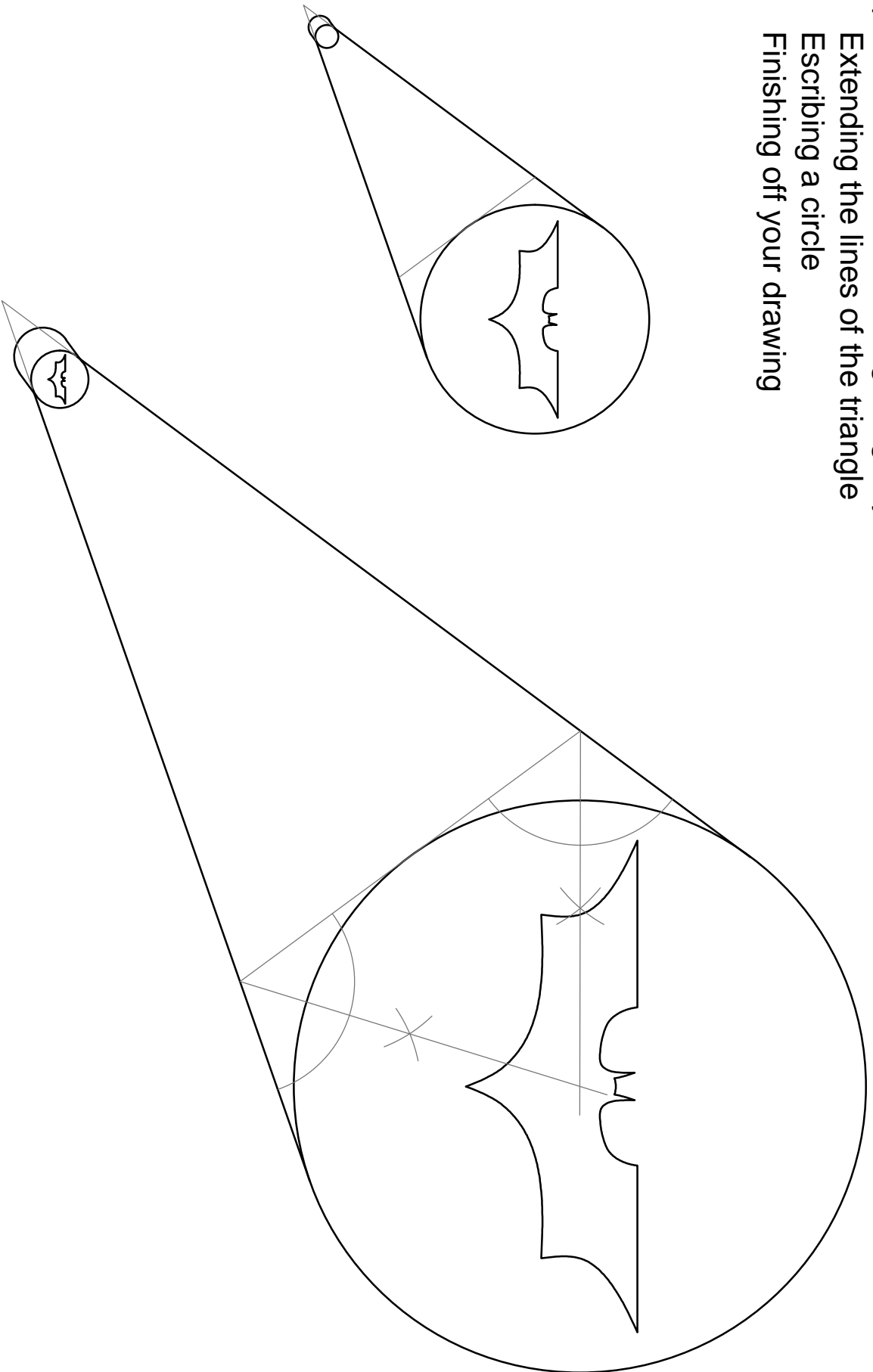

## Escribed circle exercise 2 - STARTER SHEET

Complete the bathroom cabinet design by following these steps:

- a) escribe a circle
- b) draw a circle of 22mm radius on the centre line provided

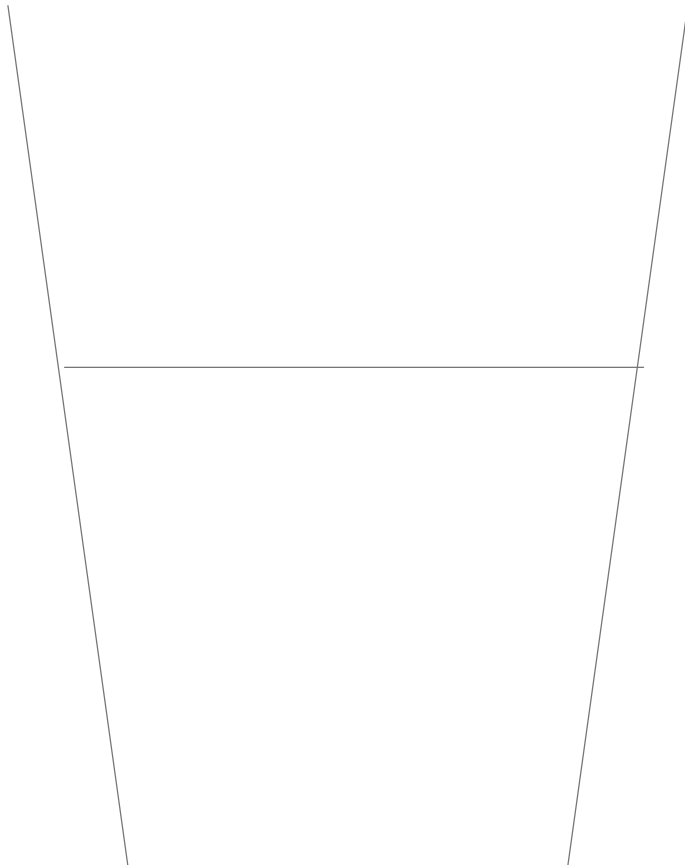
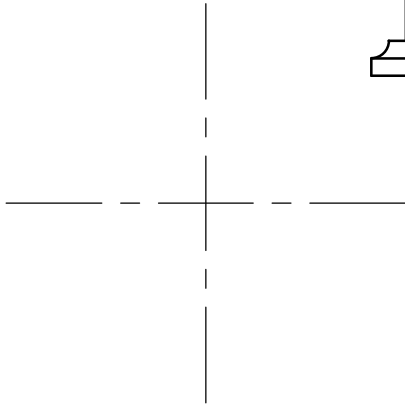
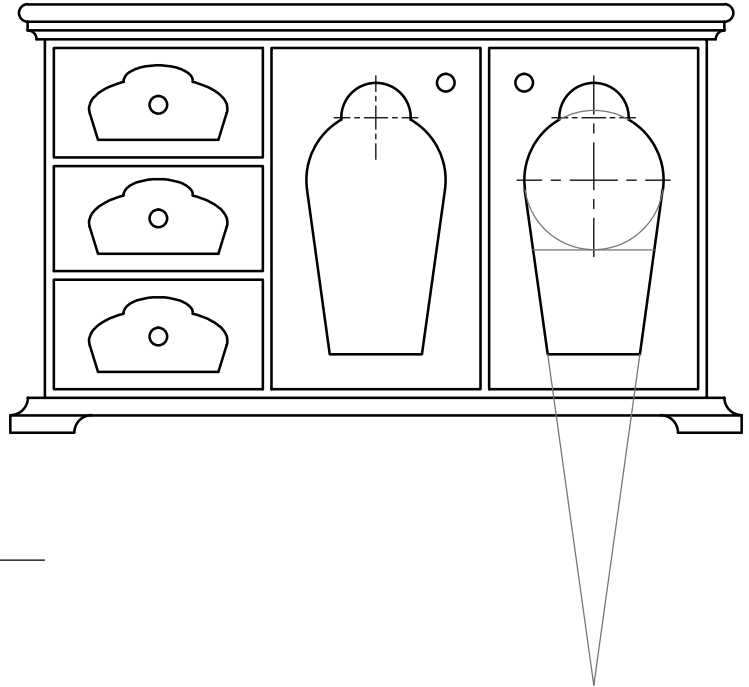



## Escribed circle exercise 2 - ANSWER SHEET

Complete the bathroom cabinet design by following these steps:

- a) escribe a circle
- b) draw a circle of 22mm radius on the centre line provided

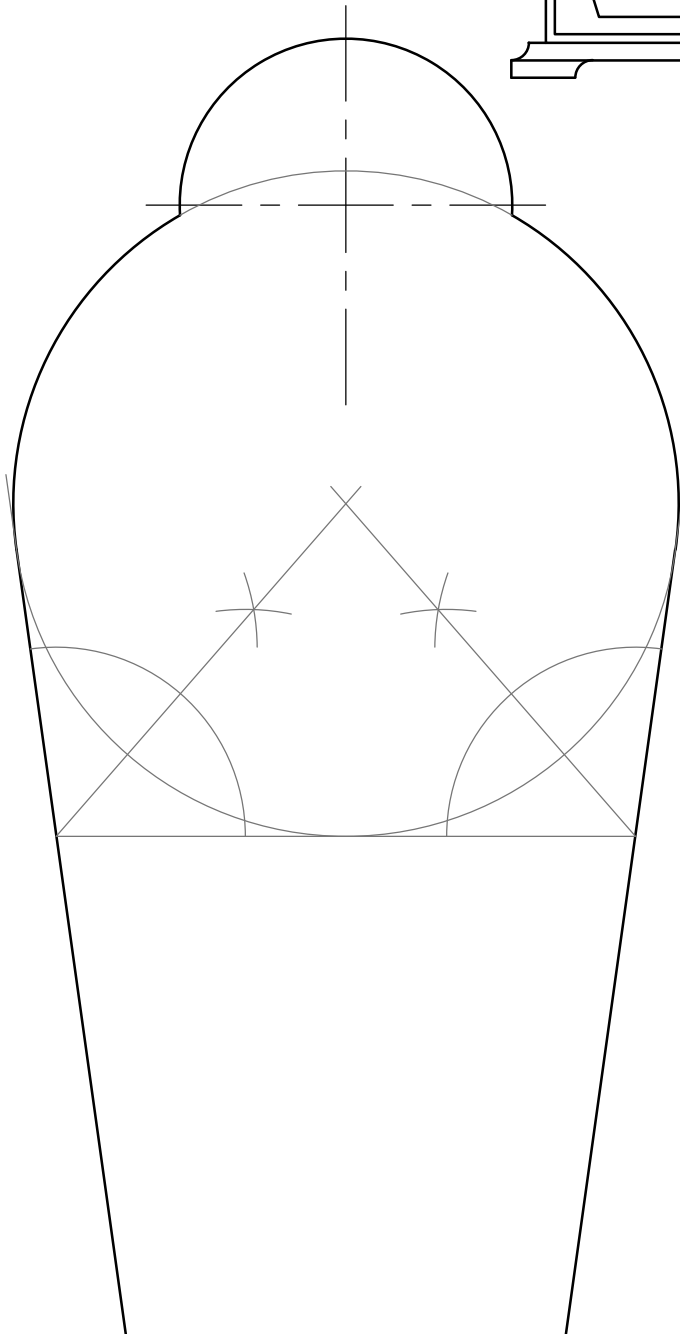
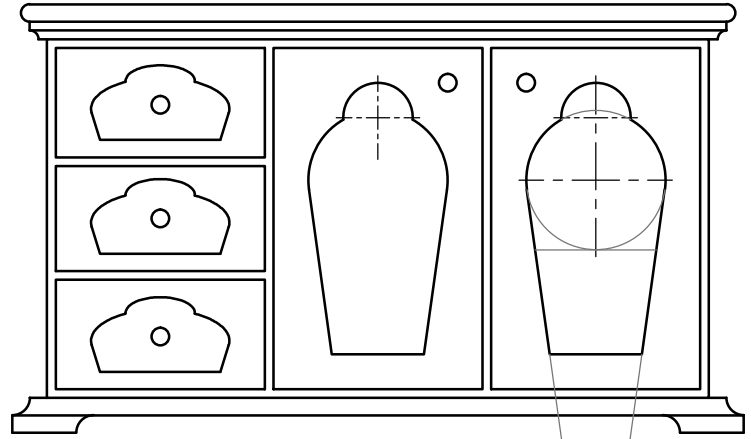

## Circumscribed circle exercise 1 - STARTER SHEET

Complete the colour wheel by:

- circumscribing a circle around the given triangle
- drawing a concentric circle of radius 75mm
- dividing the circles into 12 (using set squares)
- finishing off and colouring your drawing.

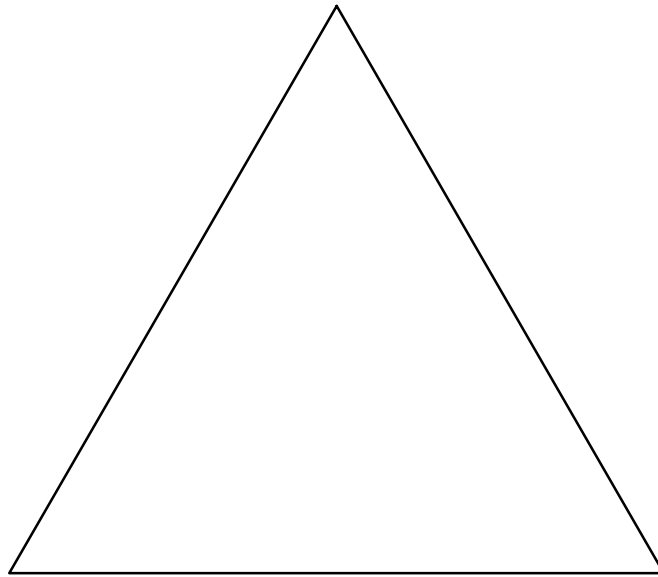
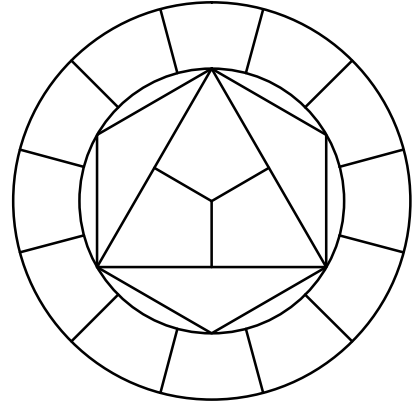

## Circumscribed circle exercise 1 - ANSWER SHEET

Complete the colour wheel by:

- circumscribing a circle around the given triangle
- drawing a concentric circle of radius 75mm
- dividing the circles into 12 (using set squares)
- finishing off and colouring your drawing.

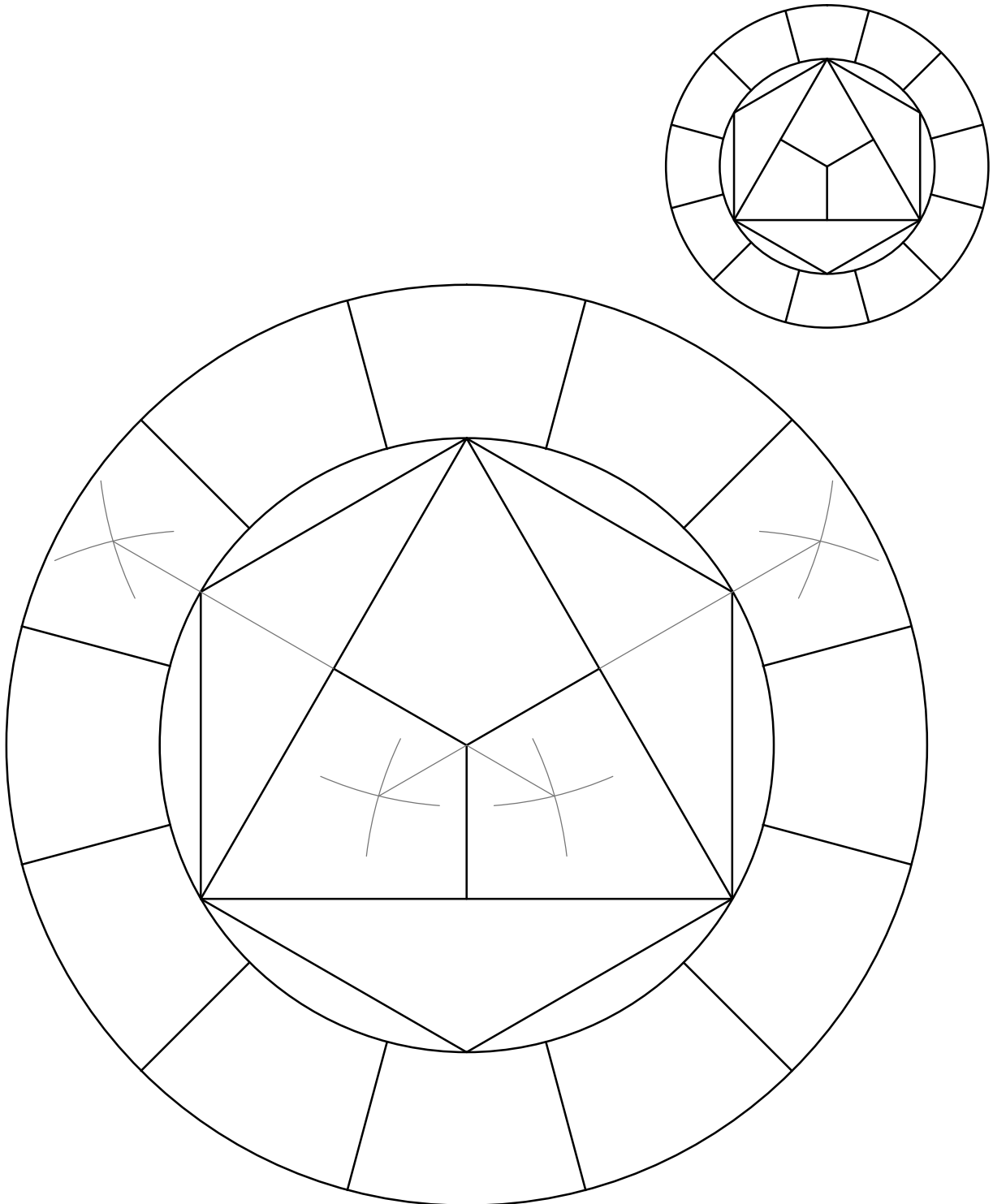

## Circumscribed circle exercise 2 - STARTER SHEET

Complete the 'Dragon Dojo' logo by circumscribing a circle to the shield.  
Draw a second circumscribed circle with a radius of 85mm.

*Hint: Treat the shield as a triangle*

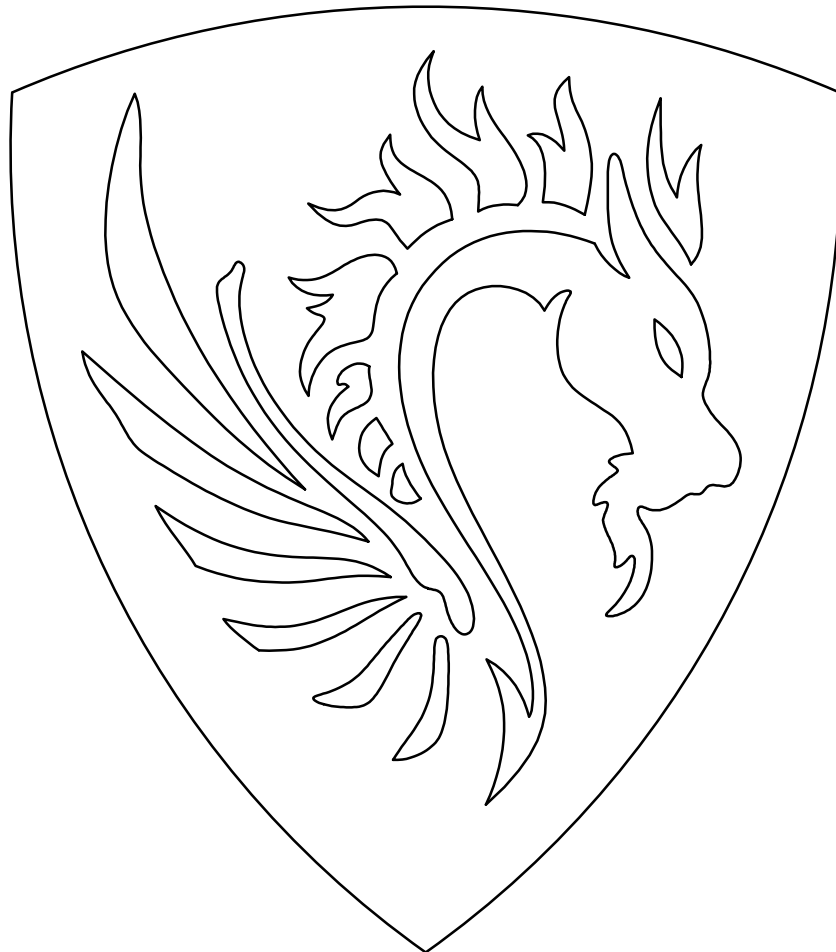

## Circumscribed circle exercise 2 - ANSWER SHEET

Complete the 'Dragon Dojo' logo by circumscribing a circle to the shield.  
Draw a second circumscribed circle with a radius of 85mm.

*Hint: Treat the shield as a triangle*

